



MAINTENANCE MANUAL

FRONT CAP ASSEMBLY 19D901913G1 FOR MVS

TABLE OF CONTENTS

	<u>Page</u>
DESCRIPTION.....	Front Cover
LIQUID CRYSTAL DISPLAY	Front Cover
CONTROL PANEL	Front Cover
CONTROL BOARD	1
CIRCUIT ANALYSIS	1
LIQUID CRYSTAL DISPLAY	1
CONTROL PANEL	1
CONTROL BOARD	1
POWER DISTRIBUTION	1
IC DATA	2
PARTS LIST.....	3
ASSEMBLY DIAGRAM	4
OUTLINE DIAGRAM.....	5
SCHEMATIC DIAGRAM.....	6

DESCRIPTION

determines the number of channels and provides the Type 99 decode option or the Public Address option.

The Front Cap Assembly consists of a Liquid Crystal Display (LCD), a Control Panel, and an internal speaker, and is interconnected to the radio by a nine pin plug and a flat ribbon cable. The microphone connector is at the bottom of the Front Cap Assembly on the Control Board.

There are seven (7) different optional interchangeable Control Panels available as follows:

- Two Channel 19B801450P1
- Two Channel with Type 99 decode 19B801450P2
- Sixteen Channel with scan 19B801450P3
- Sixteen Channel with scan and Public Address 19B801450P4
- 128 Channel with scan 19B801450P5
- 2 Channel with Public Address 19B801450P6
- Sixteen Channel with scan and Type 99 decode 19B801450P7

LIQUID CRYSTAL DISPLAY

The LCD provides all of the display indicators and the **POWER ON/OFF** switch. This assembly is mounted on the front of the Front Cap Assembly under the Control Panel and is viewed through the window on the Control Panel. The LCD receives data from the Control Board to turn on the indicators. LED's behind the LCD backlight the display for night viewing.

CONTROL PANEL

The Control Panel plugs into the Front Cap Assembly and provides all controls except the power switch. The panel



Ericsson GE Mobile Communications Inc.
Mountain View Road • Lynchburg, Virginia 24502

CONTROL BOARD

The LCD Assembly and the Control Panel are connected to the Control Board. The microprocessor on the Control Board interfaces the LCD and the Control Panel to two serial data lines for communication with the main radio microprocessor on Logic Board A1. The Control Board also contains a digital volume control and a 3 watt audio amplifier.

CIRCUIT ANALYSIS

The microprocessor (U725) on the Control Board uses two serial data lines to send and receive data with the main radio processor on Logic Board A1. Schmitt triggered hex inverters (U726) buffer the lines to reduce noise and data error problems. Both serial lines normally rest at +5 volts, with data causing the lines to go low.

LIQUID CRYSTAL DISPLAY

The LCD connects to the microprocessor output port pins through J727. Serial commands from Logic Board A1 are sent to the microprocessor on the **DISPLAY SERIAL** line through P701. The microprocessor converts the serial data to the data format needed to drive the LCD. LED's behind the LCD for backlighting receive power from **SWA+**. The **POWER** switch momentarily grounds the **POWER SW** line which feeds the A+ switching circuitry on System Board A5.

CONTROL PANEL

The Control Panel connects to the microprocessor input port pins through J726. The microprocessor port pins are normally pulled high to +5 volts through 50K ohm resistors in the microprocessor. A switch closure on the Control Panel grounds an input port line. The diodes on these lines protect the microprocessor from static discharges. The microprocessor converts each switch closure to serial data which is sent on the **KEYPAD SERIAL** line through P701 to Logic Board A1.

CONTROL BOARD

Receiver Audio

RX AUDIO from Audio Board A3 passes through the Control Board to the System Board (A5) on connectors P701 and J901. The audio is attenuated on the System Board and sent back to the Control Board. **ATTENUATED RX AUDIO** feeds the digital volume control U802.

Digital volume control U802 is equivalent to a 10K potentiometer with the wiper stepped by data from microprocessor U725. When the **VOLUME UP/DOWN** buttons are pushed on the Control Panel, the microprocessor sets the **UP/DOWN** control input on U802 to the desired direction and then toggles the **INC** (increment) line to step the potentiometer. The microprocessor provides data to the pot for 14 levels of volume. The volume setting is sent back serially to the Logic Board to be stored in the personality **EEPROM**. When the radio is turned on, the Logic Board sends this data to the Control Board to return to the same volume setting.

Resistor R811 prevents turning the volume down to zero. If no audio output is desired at the bottom step of the volume control, a short may be placed across R811.

The Automatic Gain Control (**AGC**) circuit (U803), fed by the wiper of the digital volume control, increases the apparent loudness of the radio. At low volume levels, the **AGC** circuit simply adds about 9 dB of RX audio gain. At higher audio levels, when 3 watt PA U801 is at the threshold of clipping, the circuit reduces the gain as necessary to prevent harsh clipping distortion. The AGC then functions as an unique compressor with multiple release (recovery) times providing high average audio and far less side effects than conventional compressors. The RX audio is processed so short audio peaks cause fast release times (thus increasing the average loudness); however, long audio (e.g. long phrases) with a high average level cause slower release times to reduce the annoying "rush-up" of gain and noise between words.

The AGC contains a voltage controlled amplifier (D801 and U803-A), a peak detector (U803-B and D802), and timing circuitry. Diode D801 is used as an attenuator buffered by U803-A. Normally D801 is completely off and offers no attenuation to the RX audio signal. As the control voltage from the timing circuitry increases above 5 Vdc, the current through D801 begins to increase thus decreasing the signal across the

diode. Amplifier U803-A feeds AGC peak detector U803-B and 3 watt PA U801.

The AGC control voltage is produced by a peak detector (U803-B and D802) and the timing circuitry. Peak detector U803-B amplifies the output of U803-A with a gain of 13 (22 dB). Since the timing circuitry normally rests at a 5 volt bias level, diode D802 conducts when the positive output peaks from U803-B exceed 5.5 volts. The positive peaks from D802 are filtered into a smooth DC control voltage by the timing circuitry consisting of capacitors C814 and C815 and resistors R825, R826 and R827. The increase in control voltage causes diode D801 to conduct and reduce the signal level. Since the clipping point of the 3 watt PA varies with the supply voltage, a sample of **SWA+** is applied to U803-B through resistor R823 to vary the threshold of the peak detector. Also, the gain of U803-B is relatively low for a peak detector. The low gain causes the AGC output to rise slightly as the RX audio level (or volume) increases, allowing the perceived loudness to increase at the expense of slight clipping distortion.

The output of the audio AGC feeds 3 watt audio power amplifier U801. Power amplifier U801 has a gain of 22 (27 dB). The feedback loop consisting of resistors R805 and R806 and capacitor C803 determines the amplifier gain. Resistors R803, and capacitors C804, C806 and C810 prevent high frequency oscillations.

The 3 watt PA is muted (switched off) when the **AUDIO MUTE** line is low. The **AUDIO MUTE** line is pulled high to +5 volts by an internal 50k ohm resistor in the Logic Board (A1) microprocessor. The microprocessor pulls the line low to mute the audio. The line may be externally grounded at microphone connector J725 or the System Board (A5) option connector to mute the receiver audio; however, the line may **not** be forced to +5 Vdc to unmute the audio. Grounding the line turns on Q801 which applies 1.25 Vdc to U801, Pin 2. This voltage saturates U801 causing PA output, Pin 4 to switch to ground.

The 3 watt audio output is routed to System Board A5 on **SPKR HI** through J901. **SPKR HI** is also available on the microphone connector J725. The internal speaker normally connects to the System Board to provide easy access to the speaker when servicing the radio. An alternate speaker connector J801 on the Control Board is used for the internal speaker in the remote mount option.

CG Disable Input

The Channel Guard disable input is grounded when the microphone is placed off-hook. Grounding **CG DISABLE** will place the radio into squelch operation only and stop all scanning. When the microphone is on-hook, this line is at 5 volts provided by the 50K ohm pullup resistor in microprocessor U725.

GE-STAR Input

The **GE-STAR** input to the microprocessor is used with the **GE-STAR** Encoder option when transmitting the emergency data message. The **GE-STAR** input prevents illuminating the TX indicator on the LCD when the transmitter is keyed. The input must be grounded before or simultaneously with the PTT. Once the PTT is keyed, the TX indicator will remain off if the **GE-STAR** input is ungrounded. This line normally rests at 5 volts provided by the 50K ohm pullup resistor in the microprocessor.

PUB ADD MUTE Output

The public address mute line output from the microprocessor normally rests at a logical low to keep the public address microphone audio muted on the System Board A5. If a Control Panel with the public address option is used, this line will switch to +5 volts when the PA button is pushed and the microphone PTT is keyed.

POWER DISTRIBUTION

Switched A+ from the System Board (A5) feeds the Control Board through J901. **SWA+** supplies 13 volts to 5 volt regulator U727, 3 watt audio PA U801, and the LED backlighting on the LCD Assembly.

Voltage regulator U727 supplies +5 volts to the microprocessor U725, digital volume U802, serial line buffers U726, and the LED lighting on the Control Panel. A reset circuit in U727 provides the microprocessor with a 20 milliseconds logical low pulse at power-up.

An overall Distribution Block Diagram is provided in the Service Section of this manual.

VOLTAGE REGULATOR (U727)
19A704970P1

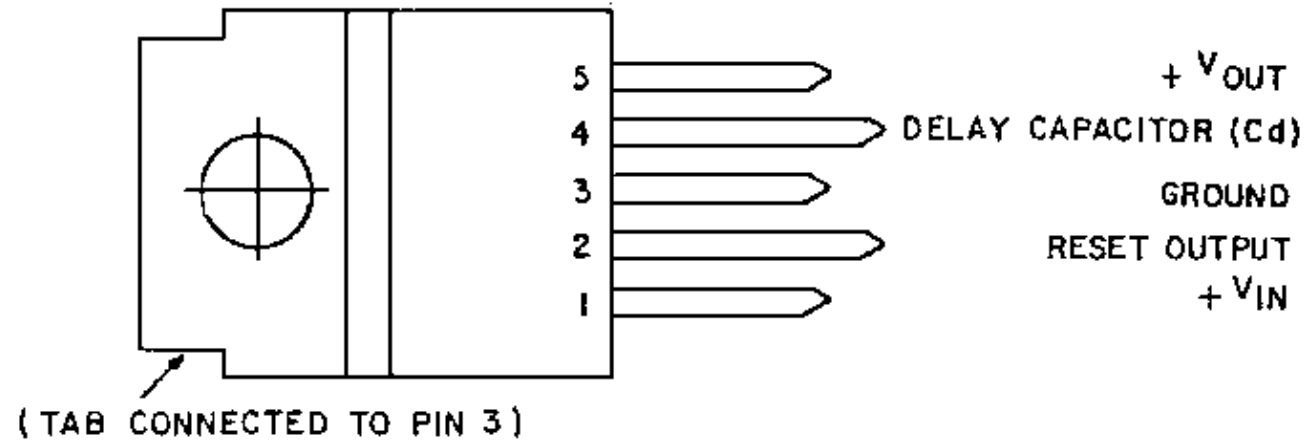

HEX SCHMITT TRIGGERED INVERTER (U726)
19A700037P313

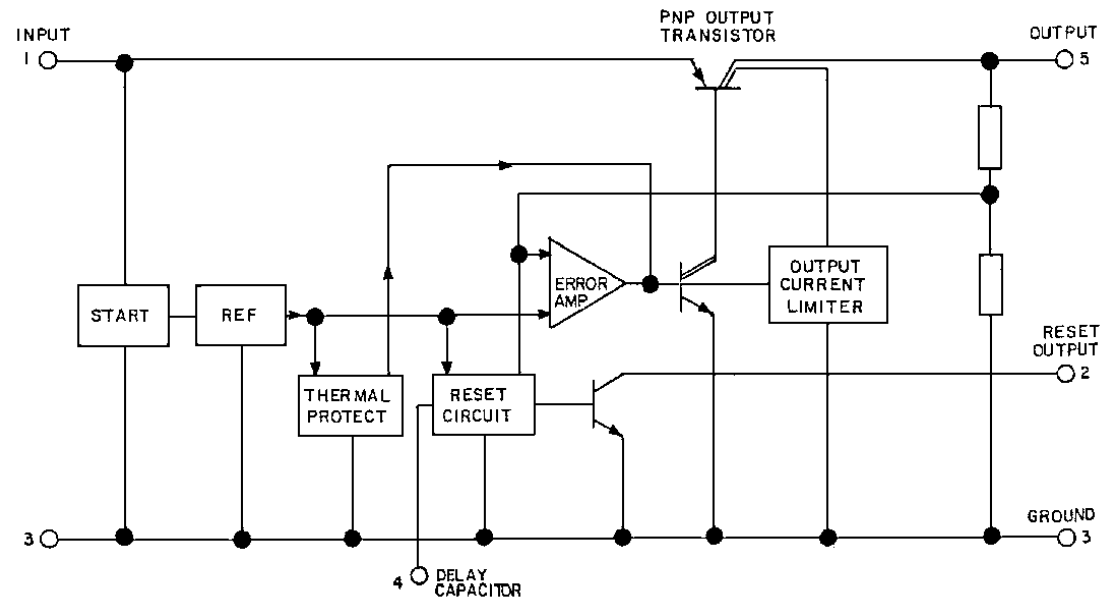
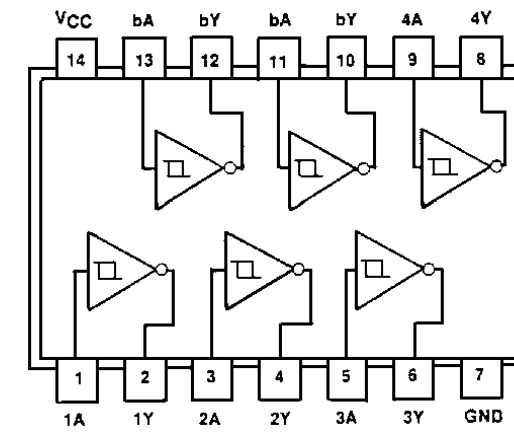

AUDIO AMPLIFIER (U801)
19A701830P1

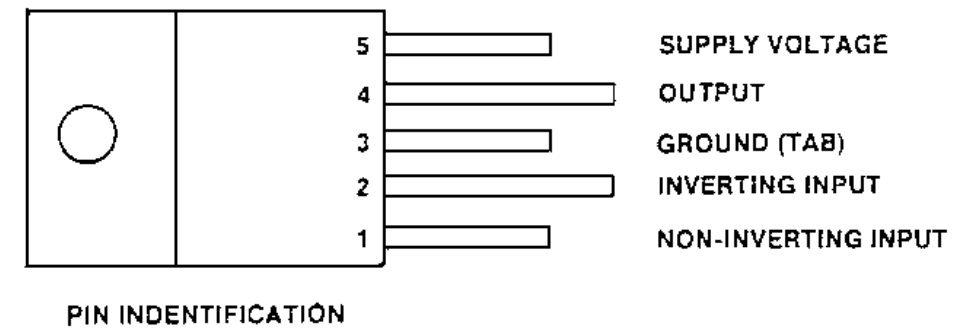

PARTS LIST

LBI-38387

SYMBOL	GE PART NO.	DESCRIPTION
A6		MVS CONTROL BOARD 19D90187563
----- CAPACITORS -----		
C726	19A700235P17	Ceramic: 22 pF ±5%, 50 VDCW.
C727	T644ACP410K	Polyester: 0.1 uF ±10%, 50 VDCW.
C728	19A701534P9	Tantalum: 47 uF ±20%, 6.3 VDCW.
C729	T644ACP410K	Polyester: 0.1 uF ±10%, 50 VDCW.
C730	19A702061P7	Ceramic: 3.3 pF ±0.5 pF, 50 VDCW, temp coef 0 ±120 PPM.
C731	19A702061P77	Ceramic: 470 pF ±5%, 50 VDCW, temp coef 0 ±30 PPM.
C734 thru C755	19A702061P77	Ceramic: 470 pF ±5%, 50 VDCW, temp coef 0 ±30 PPM.
C756 and C757	19A702061P61	Ceramic: 100 pF ±5%, 50 VDCW, temp coef 0 ±30 PPM.
C758 thru C767	19A702061P77	Ceramic: 470 pF ±5%, 50 VDCW, temp coef 0 ±30 PPM.
C802	19A702052P14	Ceramic: 0.01 uF ±10%, 50 VDCW.
C803	19A701534F7	Tantalum: 10 uF ±20%, 16 VDCW.
C804	T644ACP410K	Polyester: 0.1 uF ±10%, 50 VDCW.
C806	19A703314P10	Electrolytic: 10 uF -10+50%, 50 VDCW; sim to Panasonic LS Series.
C808	19A701225P11	Electrolytic: 470 uF -10% to +75%, 16 VDCW.
C809	19A701534P6	Tantalum: 4.7 uF ±20%, 35 VDCW.
C810 thru C813	19A702052P26	Ceramic: 0.1 uF ±10%, 50 VDCW.
C814	19A704879P5	Electrolytic: 10 uF ±20%, 16 VDCW.
C815 and C816	19A704879P1	Electrolytic: 100 uF, 6.3 VDCW.
C817	19A702061P61	Ceramic: 100 pF ±5%, 50 VDCW, temp coef 0 ±30 PPM.
----- DIODES -----		
D725	19A705313P2	Integrated Circuit: common anode, sim to DAP 801.
D726	19A705313P1	Integrated Circuit: common cathode, sim to DAN 801.
D727 thru D743	19A700028P1	Silicon: 75 mA, 75 PIV; sim to 1N4148.
D801 and D802	19A134587P2	Silicon: 2 diodes, Common Cathode; sim to BAV 70.
----- JACKS -----		
J725	19A702333P52	Printed wire, sim to Dupont 78207-110.
J726 and J727	19A705236P1	Connector, 10 contacts; sim to MICS-10-.8.
J801	19A703248P17	Post: Gold Plated, 14 mm length.
J901	19A703248P17	Post: Gold Plated, 14 mm length.
----- PLUGS -----		
P701	19B209727P31	Connector.

SYMBOL	GE PART NO.	DESCRIPTION
----- TRANSISTORS -----		
Q801	19A700022P2	Silicon, PNP: sim to 2N3906.
----- RESISTORS -----		
R725	19B800607P472	Metal film: 4.7K ohms ±5%, 1/8 w.
R726	19B800607P102	Metal film: 1K ohms ±5%, 1/8 w.
R727	19B800607P561	Metal film: 560 ohms ±5%, 1/8 w.
R728	19B800607P102	Metal film: 1K ohms ±5%, 1/8 w.
R729 thru R731	19B800607P103	Metal film: 10K ohms ±5%, 1/8 w.
R732	19B800607P102	Metal film: 1K ohms ±5%, 1/8 w.
R803	H212CRF910C	Deposited carbon: 1 ohm ±5%, 1/4 w.
R805	19B800607P221	Metal film: 220 ohms ±5%, 1/8 w.
R806	19B800607P100	Metal film: 10 ohms ±5%, 1/8 w.
R809	19B800607P102	Metal film: 1K ohms ±5%, 1/8 w.
R810	19B800607P153	Metal film: 15K ohms ±5%, 1/8 w.
R811	H212CRF110C	Deposited carbon: 100 ohms ±5%, 1/4 w.
R812	19B800607P222	Metal film: 2.2K ohms ±5%, 1/8 w.
R813	19B800607P683	Metal film: 68K ohms ±5%, 1/8 w.
R814	19B800607P103	Metal film: 10K ohms ±5%, 1/8 w.
R815	19B800607P274	Metal film: 270K ohms ±5%, 1/8 w.
R816 and R817	19B800607P333	Metal film: 33K ohms ±5%, 1/8 w.
R818	19B800607P683	Metal film: 68K ohms ±5%, 1/8 w.
R819	19B800607P103	Metal film: 10K ohms ±5%, 1/8 w.
R820	19B800607P274	Metal film: 270K ohms ±5%, 1/8 w.
R821 and R822	19B800607P103	Metal film: 10K ohms ±5%, 1/8 w.
R823	19B800607P474	Metal film: 470K ohms ±5%, 1/8 w.
R824	19B800607P124	Metal film: 120K ohms ±5%, 1/8 w.
R825	19B800607P331	Metal film: 330 ohms ±5%, 1/8 w.
R826	19B800607P472	Metal film: 4.7K ohms ±5%, 1/8 w.
R827	19B800607P223	Metal film: 22K ohms ±5%, 1/8 w.
R828	19B800607P101	Metal film: 100 ohms ±5%, 1/8 w.
----- INTEGRATED CIRCUITS -----		
U725	19A703244P50	Microcomputer (HMOS, 8-BIT).
U726	19A700037P313	Digital: Hex Schmitt-Trigger Inverter; sim to 74LS14.
U727	19A704970P1	Linear: 5 Volt Regulator with Reset Output; sim to SGS L387.
U801	19A701830P1	Linear, Audio AMPLIFIER; sim to TDA 2003.
U802	19A705180P2	Digitally Controlled Potentiometer: 40 - 10K ohms; sim to X9103P.
U803	19A701789P2	Linear: Dual Op Amp; sim to LM358.
----- CRYSTALS -----		
Y725	19A702511G28	Crystal, quartz: 3.5795 MHz.
A7	19B801459P1	LCD Assembly.
B901	19A705165P1	Loudspeaker, permanent magnet.
----- MODULE -----		
----- CABLES -----		
W4 and W5	19A705234P1	Cable assembly.

SYMBOL	GE PART NO.	DESCRIPTION
----- MISCELLANEOUS -----		
NOTE: REFER TO THE ASSEMBLY DIAGRAM ON PAGE 5 FOR THE LOCATION OF THE FOLLOWING MISCELLANEOUS PARTS.		
2	19D901890P1	Front Cap.
3	19D901889G1	Can, Shield.
4	19A705209P1	Name Plate.
5	19A705381P13008	Screw, thread forming.
6	19A702381P508	Screw, thd. form: No. 3.5-0.6 x 8.
7	19A702364P316	Machine Screw: Pan Head, Steel.
8	19A705244P2	Clip, spring tension.

PRODUCTION CHANGES
Changes in the equipment to improve performance or to simplify circuits are identified by a "Revision Letter",
which is stamped after the model number of the unit. The revision stamped on the unit includes all previous
revisions. Refer to the Parts List for the descriptions of parts affected by these revisions.

REV. A - CONTROL BOARD 19D90187563

To reduce audio oscillations when testing the Control Board
unmounted from the radio assembly. Changed C806.
C806 was T644ACP410K - Polyester: 0.1 uF ± 10%, 50 VDCW.

FRONT CAP

*COMPONENTS ADDED, DELETED OR CHANGED BY PRODUCTION CHANGES

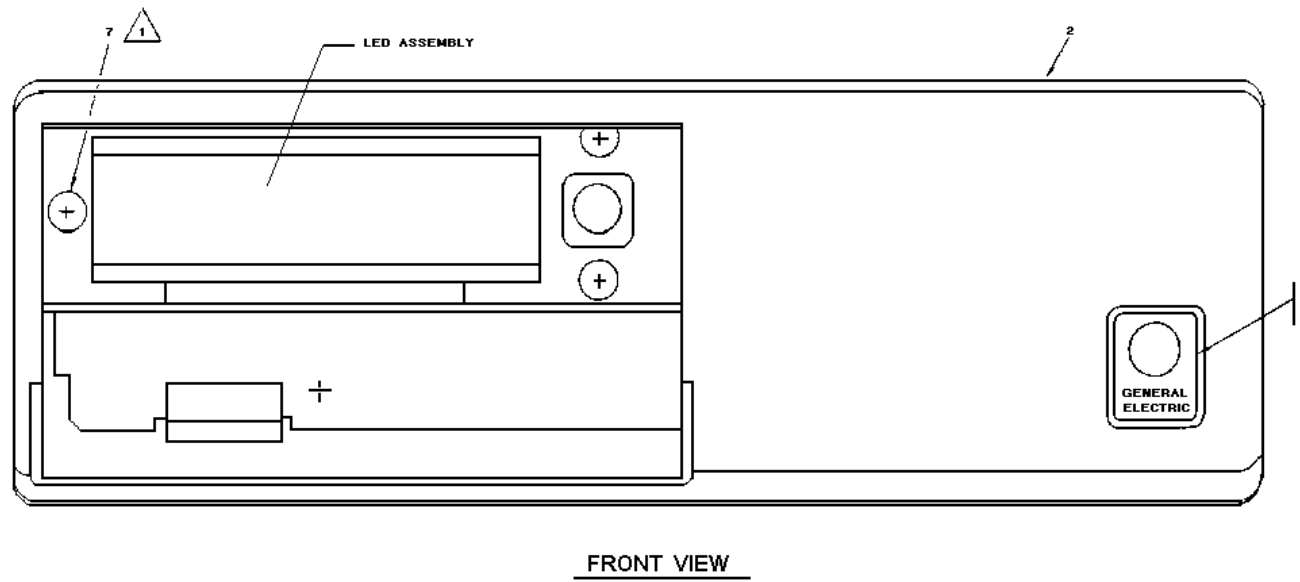
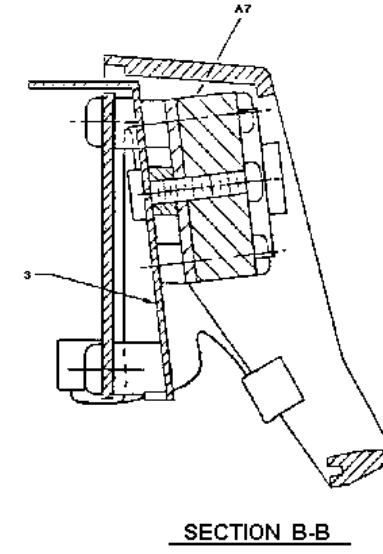
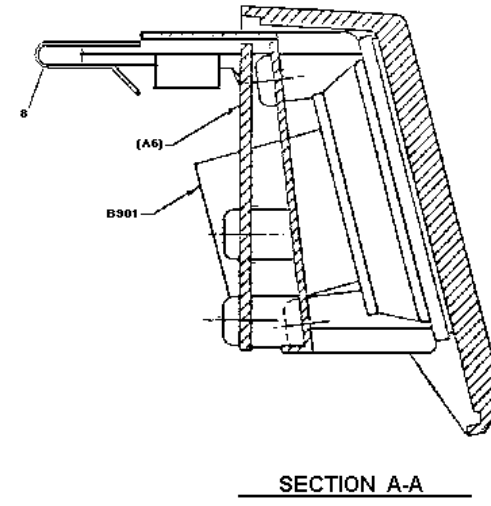
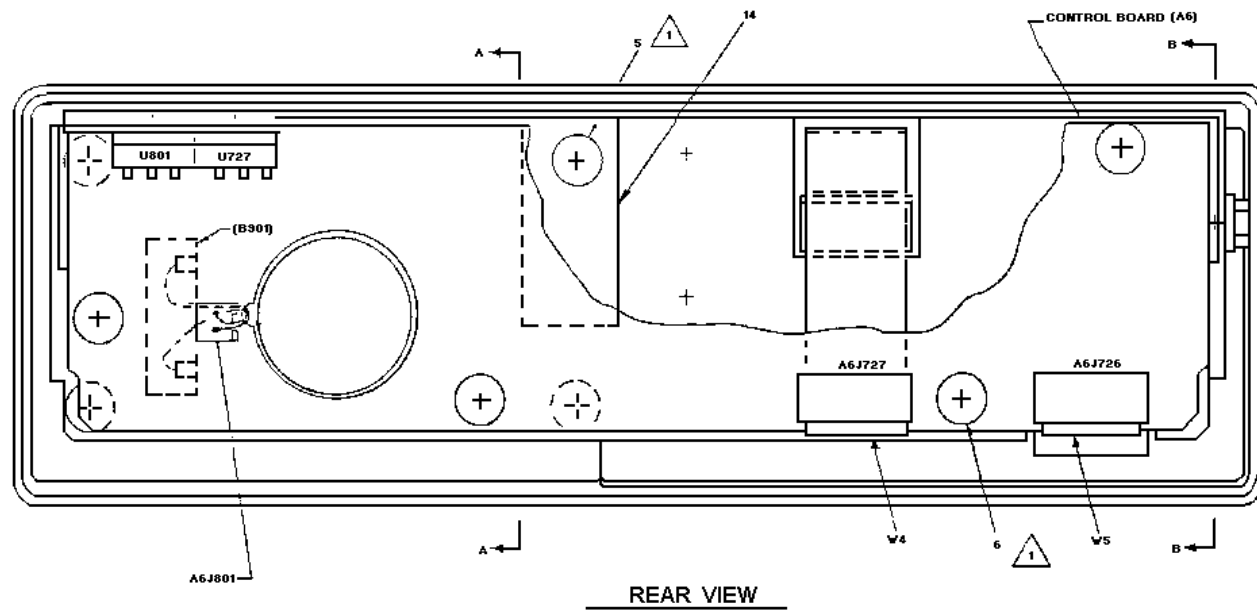

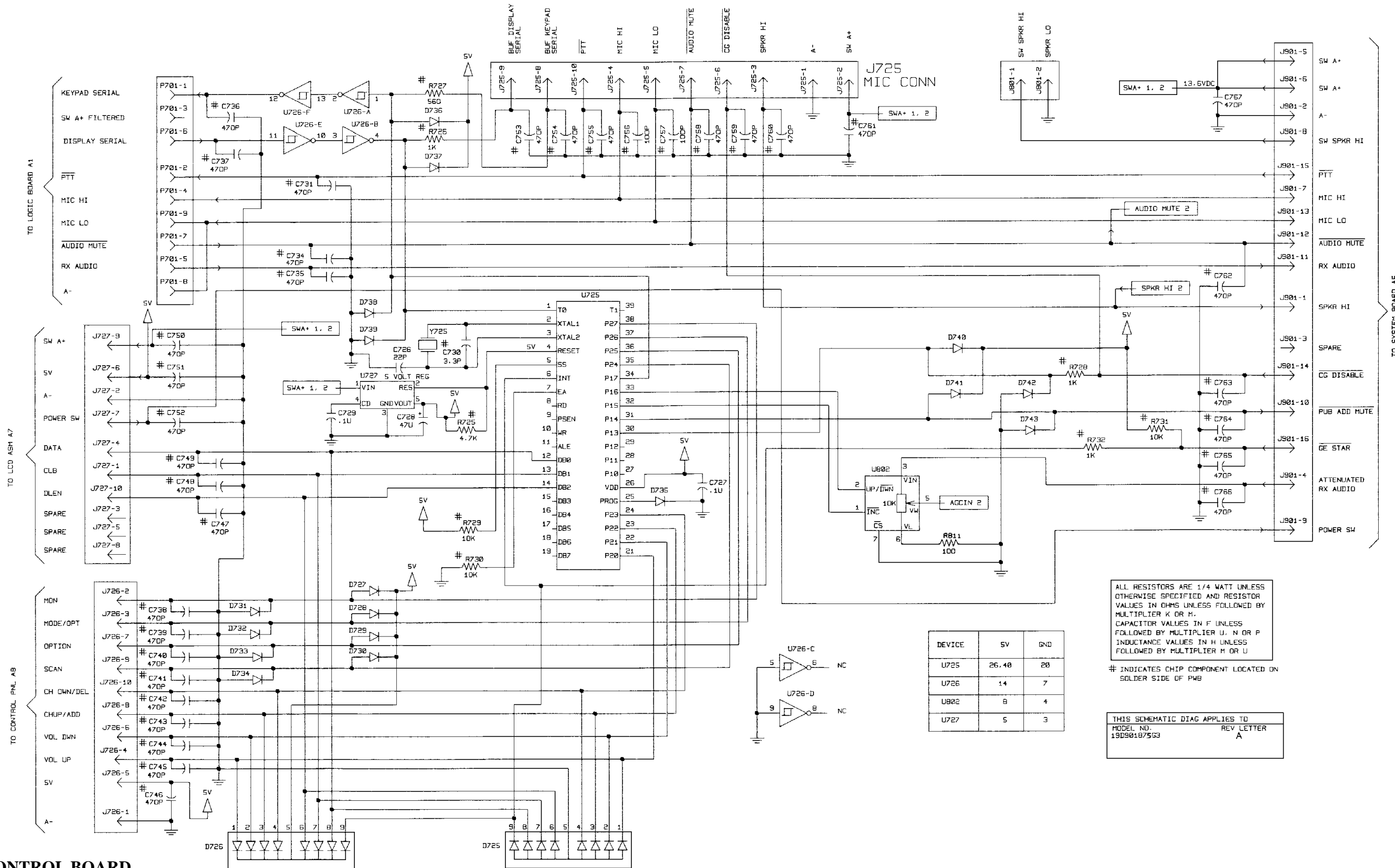

**CONTROL BOARD
19D901875G3**

(19D902297, Sh. 1, Rev. 1)

U803 AUDIO AGC

U801 3W AUDIO PA

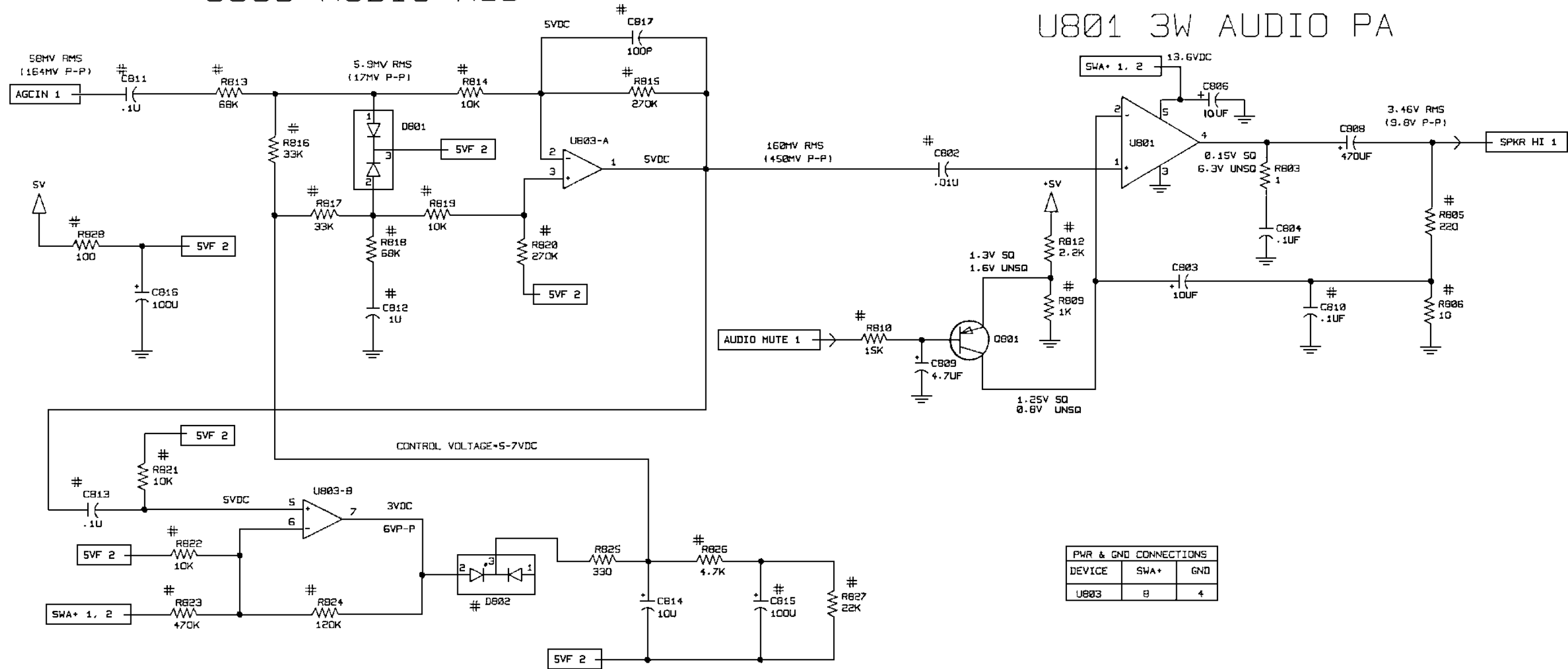

U801 & U803
CONTROL BOARD
19D901875G3