

MAINTENANCE MANUAL FRONT PANEL CMD-333 FOR MLS TWO-WAY MOBILE RADIOS

TABLE OF CONTENTS

	<u>Page</u>
DESCRIPTION	1
CIRCUIT ANALYSIS	1
PARTS LIST	3
SCHEMATIC DIAGRAMS:	
Two Channel (CMD-318)	4
Eight Channel (CMD-319A)	5
Eight Channel (CMD-319B)	6
Sixteen Channel (CMD-320A)	7
Sixteen Channel (CMD-320B)	8
OUTLINE DIAGRAMS:	
Two Channel (CMD-318)	9
Eight Channel (CMD-319A/B)	10
Sixteen Channel (CMD-320A/B)	11

DESCRIPTION

Front Panel CMD-333 (A801) for the MLS Two-Way FM mobile radio is made of highly durable plastic and has rounded corners and recessed controls and indicators for passenger safety. The Front Panel interfaces with the MLS radio to provide a POWER on/off switch, a VOLUME, MAX/MIN switch, a MONITOR switch, a FREQUENCY, ADD/DELETE switch and a SCAN on/off switch. The Front Panel also provides XMIT and BUSY indicators, a CHANNEL 1 or CHANNEL 2 indicator or a 7 - segment eight or sixteen channel digital display. The panel also provides indicators for Priority 1 (P1), Priority 2 (P2), SCAN and transmit scan, S.

This Front Panel consists of Control Unit A804-1 and a 4-ohm speaker. The Control Unit (A804-1) consists of one of five plug-in modules as follows:

- CMD-318 (Two-Channel Plug-In Module)
- CMD-319A (Eight Channel Plug-In Module)
- CMD-319B (Eight Channel, Two Priority Scan Plug-In Module)
- CMD-320A (Sixteen Channel Plug-In Module)
- CMD-320B (Sixteen Channel, Two Priority Scan Plug-In Module)

CIRCUIT ANALYSIS

The Front Panel/Control unit interfaces with the MLS radio through connector J801, flexible circuit ribbon cable ZC801 and connector J704 on System Control 1/Synthesizer Board A801 (refer to the System Interconnection Diagram in the applicable Maintenance Manual). The internal speaker (SP801) connects to connector J702, also on the A801 board.

When the radio is turned on through the power switch on the front panel through J801-23 (POWON), the MSD DRV control line (J801-24) for the two frequency radio or the LSB DRV control line (J801-19) for the eight or 16 channel radio goes low. In a two frequency radio, the channel selected by the CHANNEL, CHAN 1 or CHAN 2 switch through J801-13 or J801-15 respectively will determine which LED channel indicator (CD805 or CD806) will light by applying +5 volts from the display drivers on System Control 1 board to either J801-12 for channel 1 or J801-14 for channel 2.

In an eight channel radio, the display drivers on the System Control 1/Synthesizer Board drive each segment control line (A through G) to light the display and indicate the selected operating channel. The segment control lines are J801-4, 6, 8, 10, 12, 14 and 16.



In a 16 channel radio the MSB DRV line and the LSB DRV line alternately go low to display the 10^0 and 10^1 digits for the selected channel. This switching rate is fast enough that both displays appear to be on at the same time. These channels are selected by the ADD or DELETE switches through J801-13 (CH-UP) or J801-15 (CH-DOWN) respectively.

XMIT LED indicators CD801 and CD802 and BUSY LED indicators CD803 and CD804 light as +5 volts is applied to J801-22 when the transmit circuit is keyed or to J801-20 when the receive channel is busy.

The volume for the MLS radio is controlled through J801-3 (VOL-UP) and J801-2 (VOL-DOWN).

A MONITOR switch disables Channel Guard through J801-9 (MONI) so that the operator can monitor a non-Channel Guarded signal.

In an eight or 16 channel radio equipped with SCAN, the SCAN LED indicator CD806 (CMD-319B), CD807 (CMD-320B) will light when the SCAN/P1 control line is high and the LSB DRV line is low. The P1 (Priority 1) LED indicator CD807 (CMD319B), CD808 (CMD-320B) will light when J801-9 is high and the MSB DRV line goes low. The P2 (Priority 2) LED indicator CD808 (CMD-319B), CD809 (CMD-320B) will light when the BUSY/P2 line is high and LSB DRV line is low. Also, the "S" (Scan) LED indicator CD809 (CMD-319B), CD810 (CMD-320B) will light when the XMIT/S control line is high and the LSB DRV line is low. This indicator indicates that the radio is in the SCAN mode when the transmit circuit is keyed. The SCAN mode is activated by a switch labeled SCAN through J801-11 (SCAN).

FRONT PANEL/CONTROL
CMD-333
ISSUE 2

SYMBOL	PART NO.	DESCRIPTION
STANDARD 2 CHANNEL CMD-318		
----- DIODES -----		
CD801 and CD802	B19/5TXBG00035	Optoelectronic: red; sim to Stanley BR2222S-B1.
CD803 and CD804	B19/5TXBG00036	Optoelectronic: green; sim to Stanley BG2222S-B1.
CD805 and CD806	B19/5TXBG00026	Optoelectronic: green; sim to Rohm LD-101MG.
----- JACKS -----		
J801	B19/5JWB800182	Connector; 24 pin.
----- RESISTORS -----		
R801 and R802	B19/5REAG00574	Metal film: 1.5K ohms $\pm 5\%$, 200 VDCW, 1/8 W.
R803 and R804	B19/5REAG00930	Metal film: 51 ohms $\pm 5\%$, 200 VDCW, 1/8 W.
----- SPEAKERS -----		
SP801	B19/5USAP00061	Speaker: 4 ohms, 4 W.
----- CABLES -----		
ZC801	B19/5ZCCL00034	Flexible Ribbon Cable.
ZC806	B19/6ZCFD00168	Speaker Cable.
OPTIONAL 8 CHANNEL CMD-319A		
----- DIODES -----		
CD801 and CD802	B19/5TXBG00035	Diode, optoelectronic: red; sim to Stanley BR2222S-B1.
CD803 and CD804	B19/5TXBG00036	Diode, optoelectronic: green; sim to Stanley BG2222S-B1.
CD805	B19/5TZCU00033	Diode, optoelectronic: green; sim to Rohm LA-301ML.
----- JACKS -----		
J801	B19/5JWB800182	Connector: 24 pin.
----- RESISTORS -----		
R801 and R802	B19/5REAG00574	Metal film: 1.5K ohms $\pm 5\%$, 200 VDCW, 1/8 W.
R803 and R804	B19/5REAG00930	Metal film: 51 ohms $\pm 5\%$, 200 VDCW, 1/8 W.
R809 thru R815	B19/5REAG00930	Metal film: 51 ohms $\pm 5\%$, 200 VDCW, 1/8 W.
OPTIONAL 8 CHANNEL WITH PRIORITY SCAN CMD-319B		
----- DIODES -----		
CD801 and CD802	B19/5TXBG00035	Diode, optoelectronic: red; sim to Stanley BR2222S-B1.

SYMBOL	PART NO.	DESCRIPTION
CD803 and CD804	B19/5TXBG00036	Diode, optoelectronic: green; sim to Stanley BG2222S-B1.
CD805	B19/5TZCU00033	Diode, optoelectronic: green; sim to Rohm LA-301ML.
CD806 thru CD809	B19/5TXBG00023	Diode, optoelectronic: red; sim to Stanley BR3432S.
----- JACKS -----		
J801	B19/5JWB800182	Connector: 24 pin.
----- RESISTORS -----		
R801 and R802	B19/5REAG00574	Metal film: 1.5K ohms $\pm 5\%$, 200 VDCW, 1/8 W.
R803 and R804	B19/5REAG00930	Metal film: 51 ohms $\pm 5\%$, 200 VDCW, 1/8 W.
R805 thru R808	B19/5REAG00574	Metal film: 1.5K ohms $\pm 5\%$, 200 VDCW, 1/8 W.
R809 thru R815	B19/5REAG00930	Metal film: 51 ohms $\pm 5\%$, 200 VDCW, 1/8 W.
OPTIONAL 16 CHANNEL CMD-320A		
----- DIODES -----		
CD801 and CD802	B19/5TXBG00035	Diode, optoelectronic: red; sim to Stanley BR2222S-B1.
CD803 and CD804	B19/5TXBG00036	Diode, optoelectronic: green; sim to Stanley BG2222S-B1.
CD805 and CD806	B19/5TZCU00033	Diode, optoelectronic: green; sim to Rohm LA-301ML.
----- JACKS -----		
J801	B19/5JWB800182	Connector: 24 pin.
----- RESISTORS -----		
R801 and R802	B19/5REAG00574	Metal film: 1.5K ohms $\pm 5\%$, 200 VDCW, 1/8 W.
R803 and R804	B19/5REAG00930	Metal film: 51 ohms $\pm 5\%$, 200 VDCW, 1/8 W.
R809 thru R815	B19/5REAG00930	Metal film: 51 ohms $\pm 5\%$, 200 VDCW, 1/8 W.
OPTIONAL 16 CHANNEL WITH SCAN CMD-320B		
----- DIODES -----		
CD801 and CD802	B19/5TXBG00035	Diode, optoelectronic: red; sim to Stanley BR2222S-B1.
CD803 and CD804	B19/5TXBG00036	Diode, optoelectronic: green; sim to Stanley BR2222S-B1.
CD805 and CD806	B19/5TZCU00033	Diode, optoelectronic: green; sim to Rohm LA-301ML.
CD807 thru CD810	B19/5TXBG00023	Diode, optoelectronic: red; sim to Stanley BR3432S.
----- JACKS -----		
J801	B19/5JWB800182	Connector: 24 pin.
----- RESISTORS -----		
R801 and R802	B19/5REAG00574	Metal film: 1.5K ohms $\pm 5\%$, 200 VDCW, 1/8 W.
R803 and R804	B19/5REAG00930	Metal film: 51 ohms $\pm 5\%$, 200 VDCW, 1/8 W.
R805 thru R808	B19/5REAG00574	Metal film: 1.5K ohms $\pm 5\%$, 200 VDCW, 1/8 W.
R809 thru R815	B19/5REAG00930	Metal film: 51 ohms $\pm 5\%$, 200 VDCW, 1/8 W.

*COMPONENTS ADDED, DELETED OR CHANGED BY PRODUCTION CHANGES

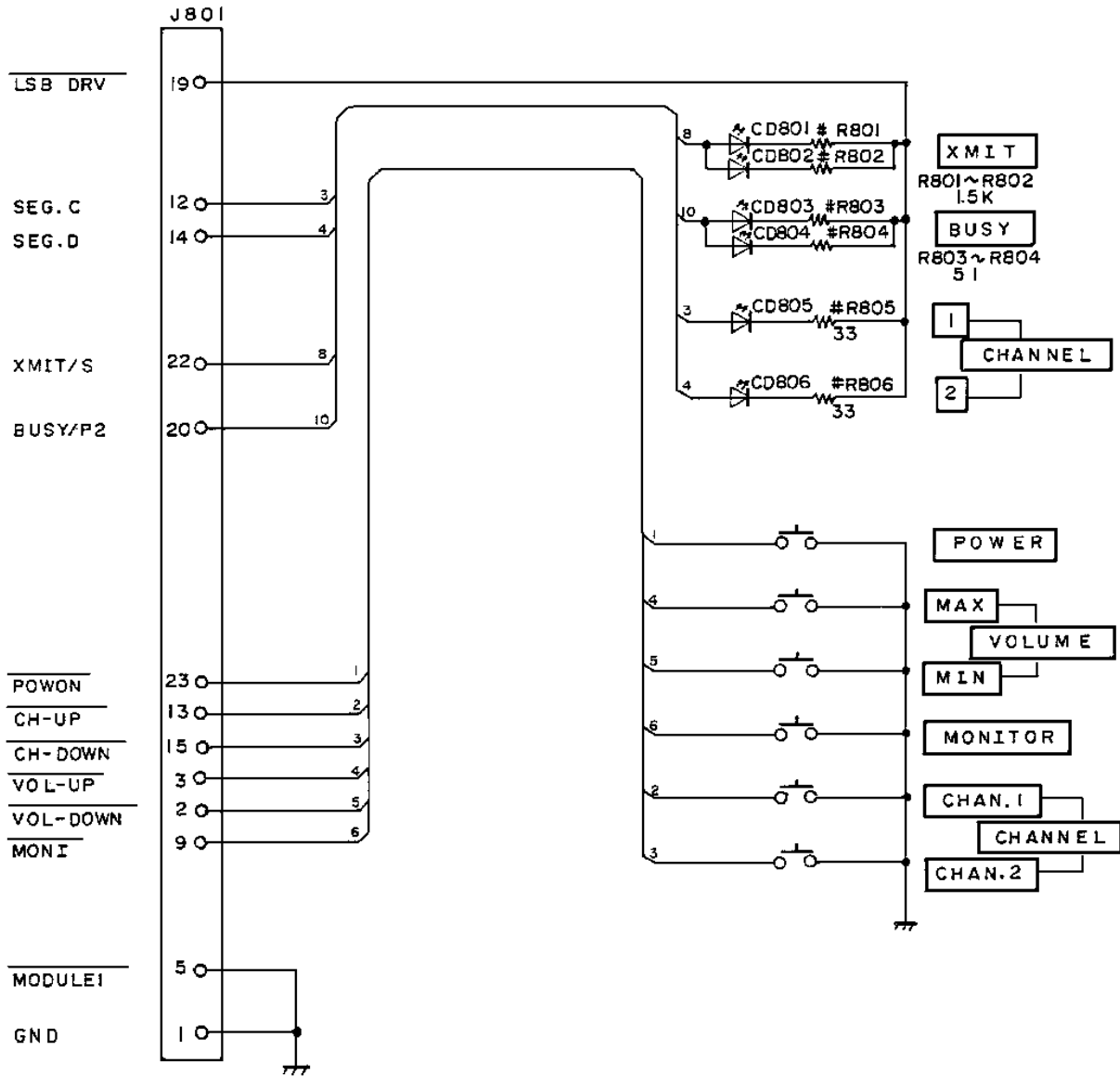

NOTES:
 ALL RESISTORS ARE 1/8 WATT UNLESS OTHERWISE SPECIFIED.
 RESISTOR VALUES IN Ω UNLESS FOLLOWED BY MULTIPLIER K OR M.

Two Channel
 Plug-In Module
 DD00-CMD-318

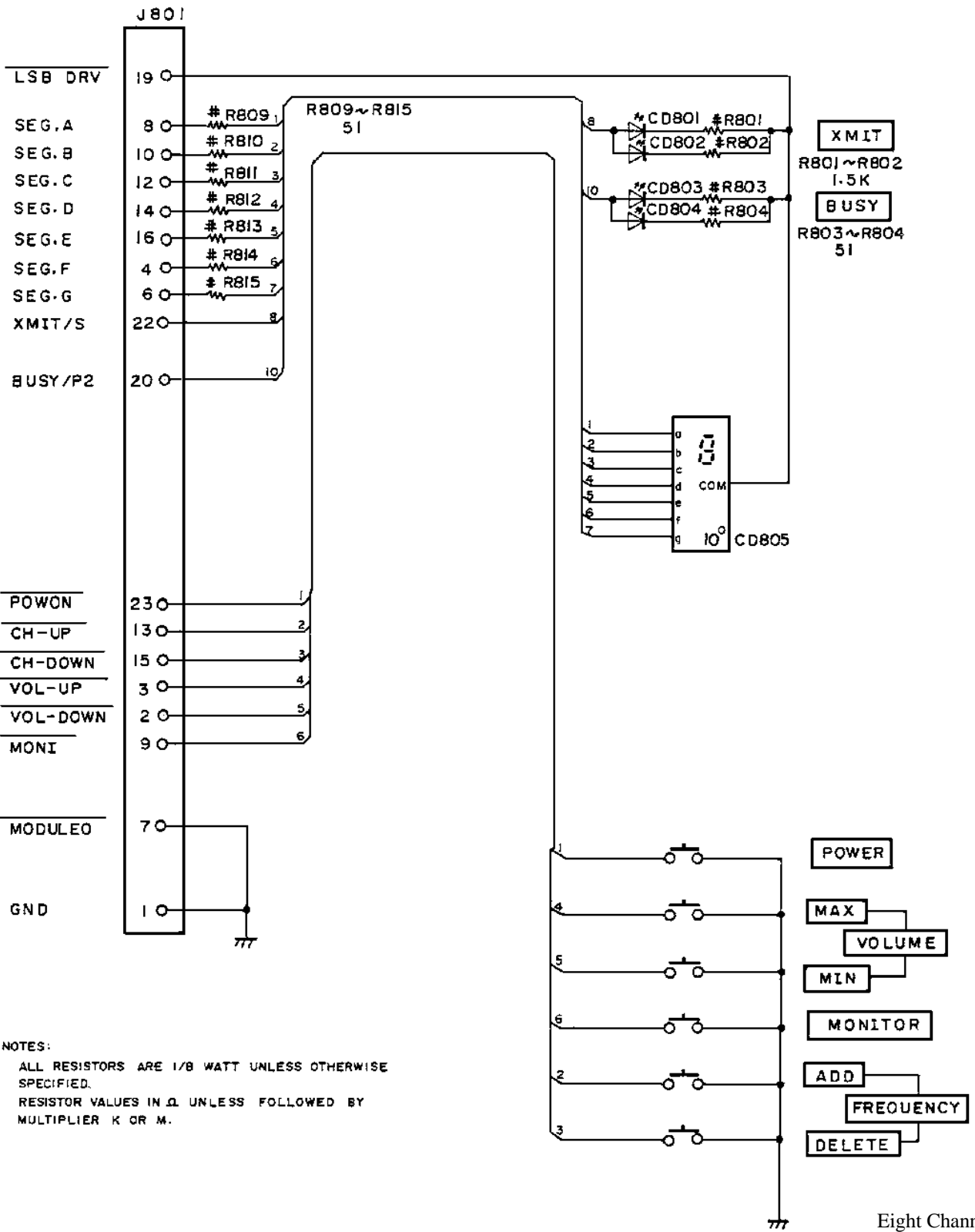

NOTES:
 ALL RESISTORS ARE 1/8 WATT UNLESS OTHERWISE SPECIFIED.
 RESISTOR VALUES IN Ω UNLESS FOLLOWED BY MULTIPLIER K OR M.

Eight Channel Plug-In Module DD00-CMD-319A

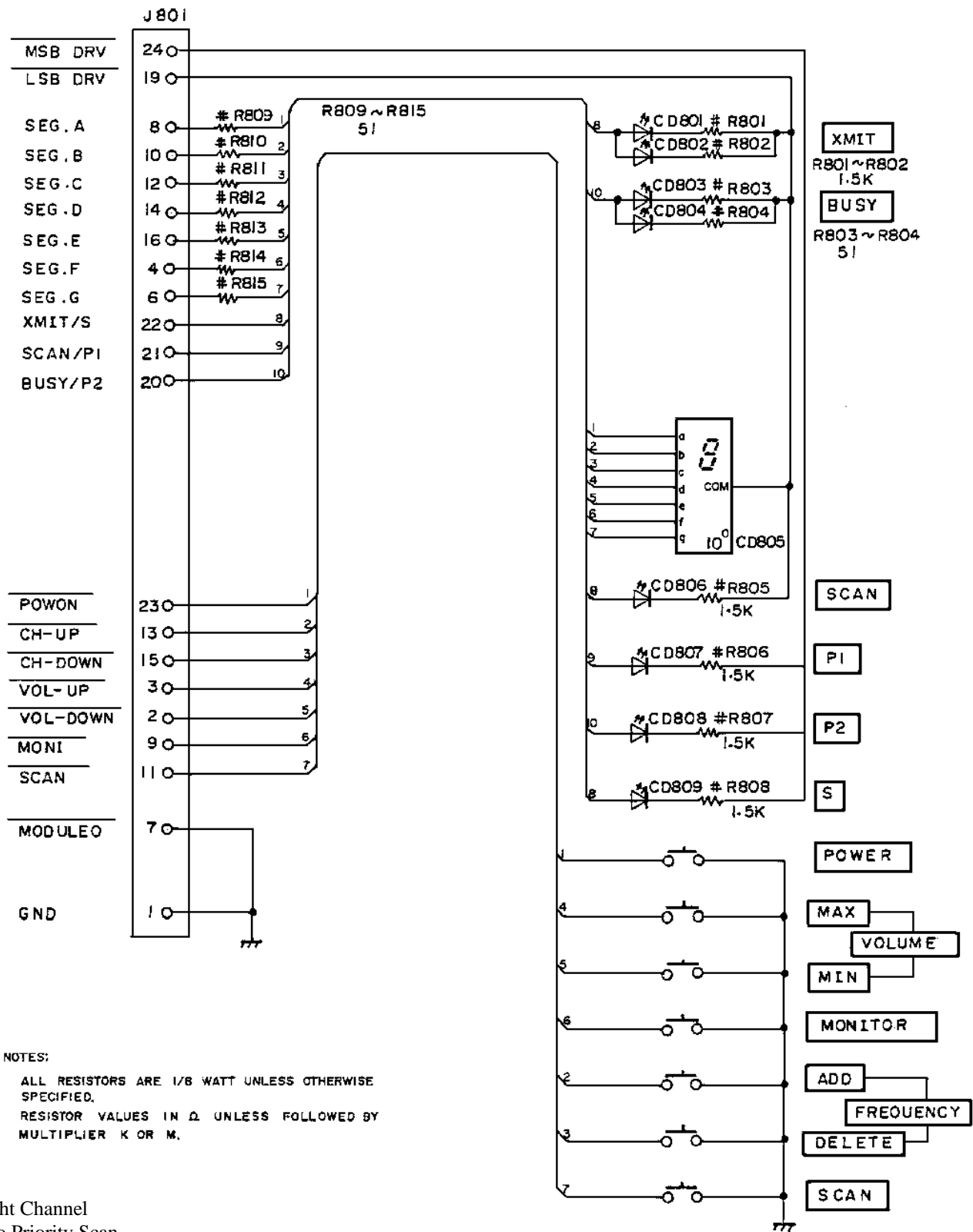

Eight Channel
 Two Priority Scan
 Plug-In Module
 DD00-CMD-319B

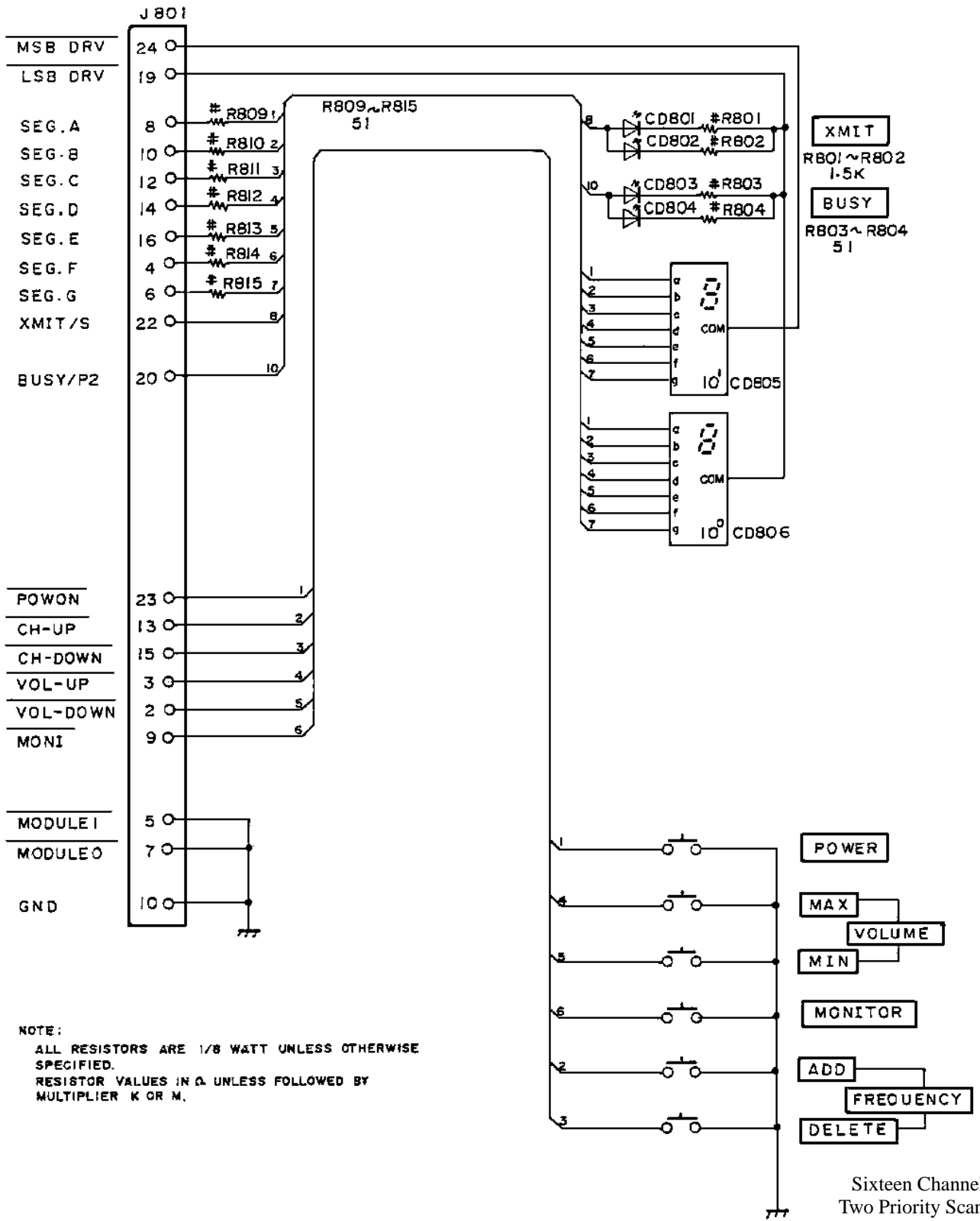

Sixteen Channel
 Two Priority Scan
 Plug-In Module
 DD00-CMD-320A

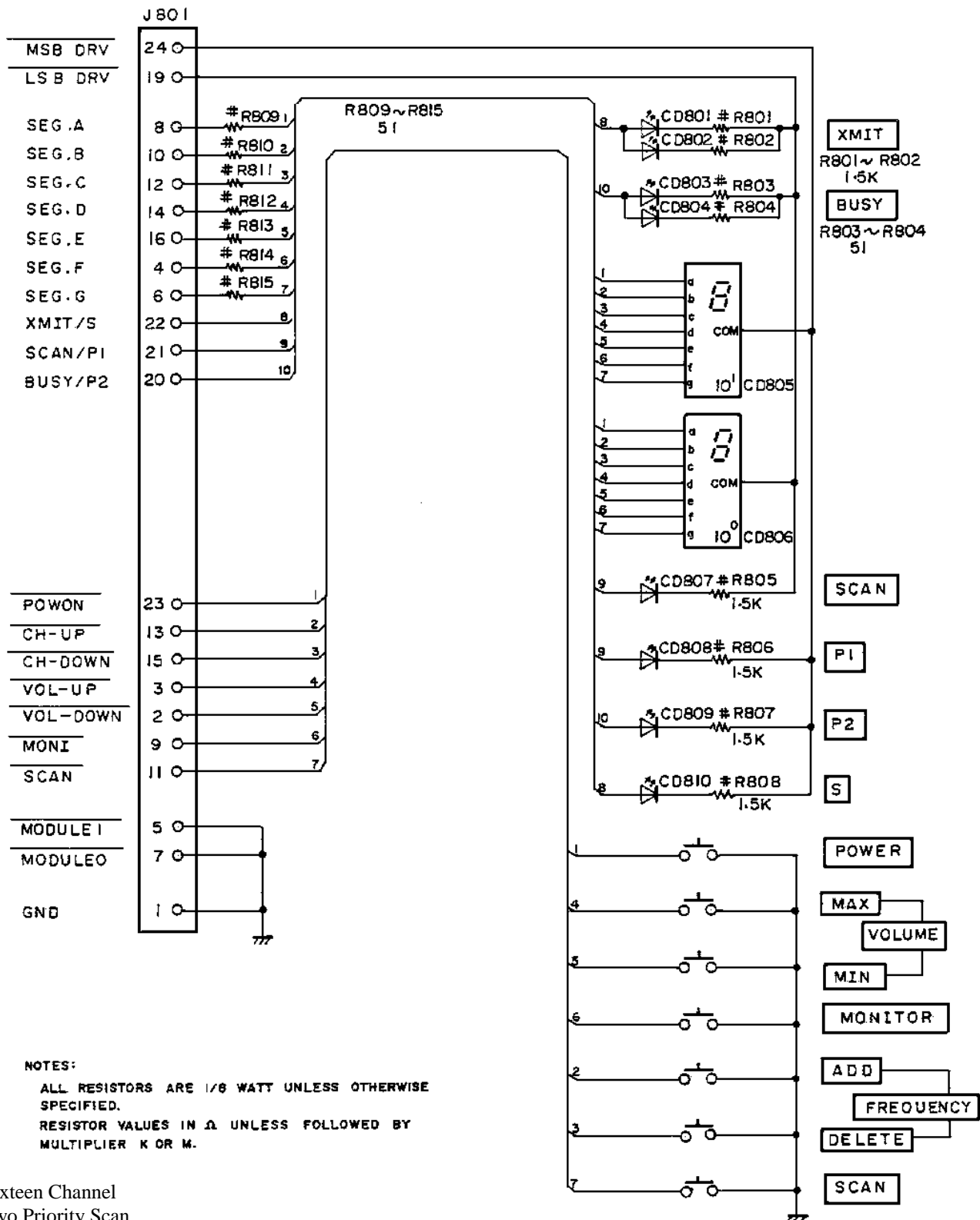

NOTES:
 ALL RESISTORS ARE 1/8 WATT UNLESS OTHERWISE SPECIFIED.
 RESISTOR VALUES IN Ω UNLESS FOLLOWED BY MULTIPLIER K OR M.

Sixteen Channel
 Two Priority Scan
 Plug-In Module
 DD00-CMD-320B

COMPONENT SIDE

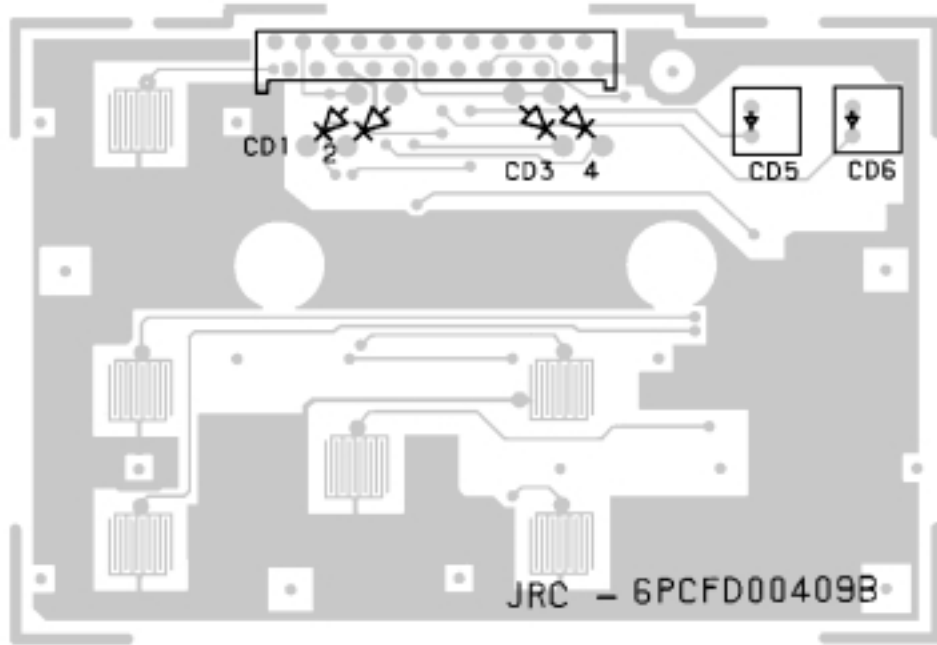

SOLDER SIDE

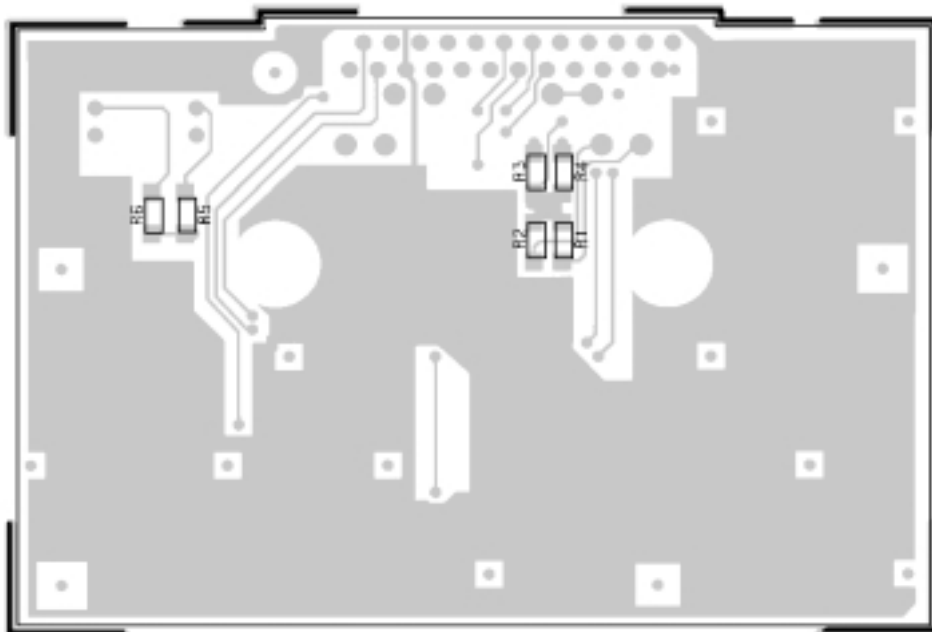

(JRC-6PCFD00409B)

Two Channel
Plug-In Module
DD00-CMD-318

COMPONENT SIDE

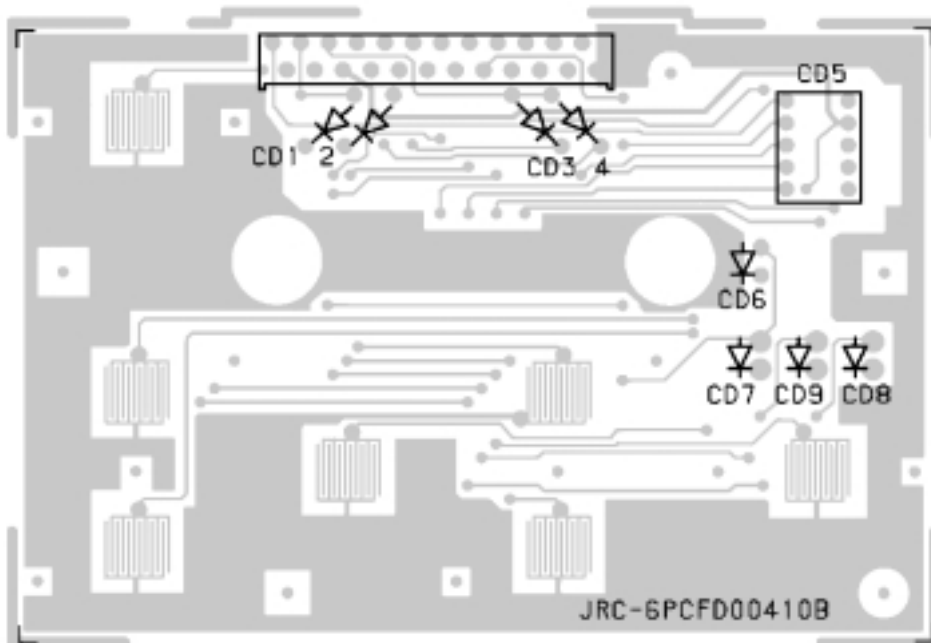

SOLDER SIDE

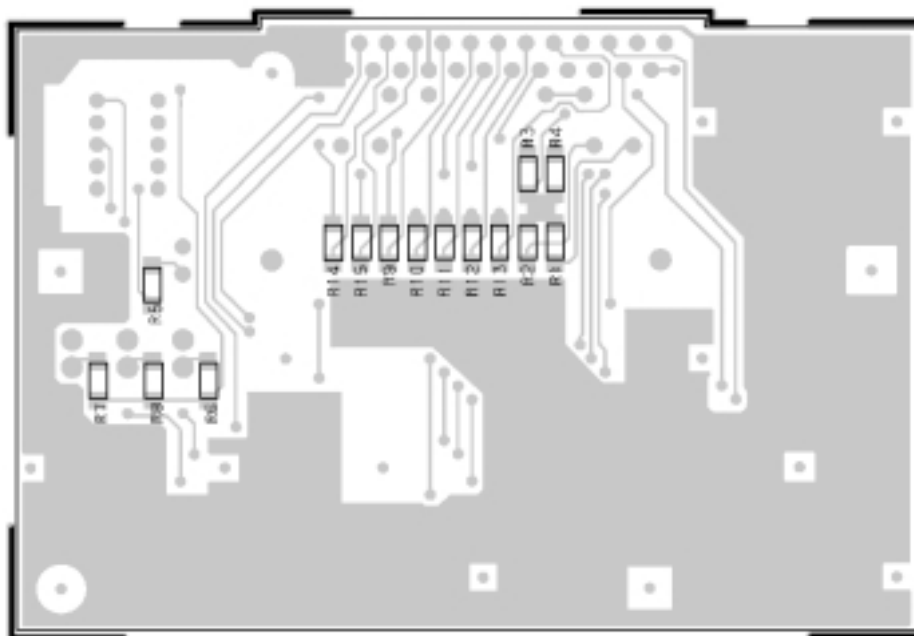

(JRC-6PCFD00410B)

Eight Channel
Plug-In Module

COMPONENT SIDE

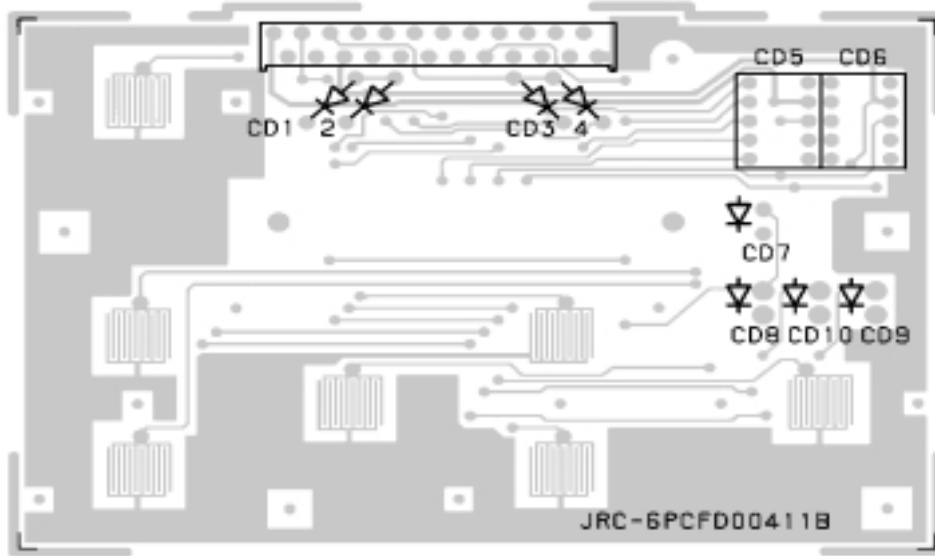

SOLDER SIDE

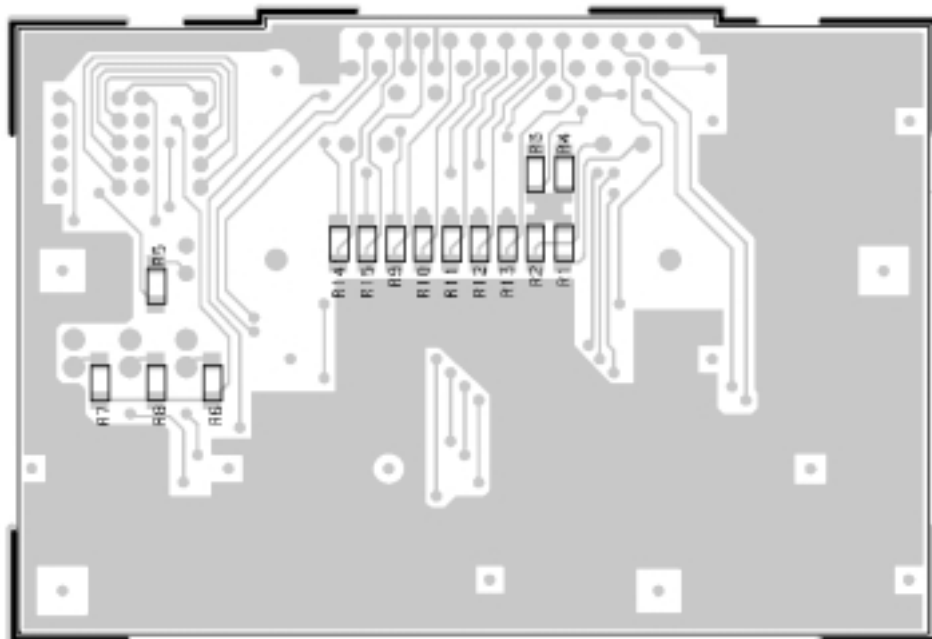

(JRC-6PCFD00411B)

Sixteen Channel
Plug-In Module
DD00-CMD-320A/B

Ericsson Inc.
Private Radio Systems
Mountain View Road
Lynchburg, Virginia 24502
1-800-528-7711 (Outside USA, 804-592-7711)

Printed in U.S.A.